

KS0835F

RING Subscriber Line Interface Circuit (RING SLIC) MODULE

Product Description

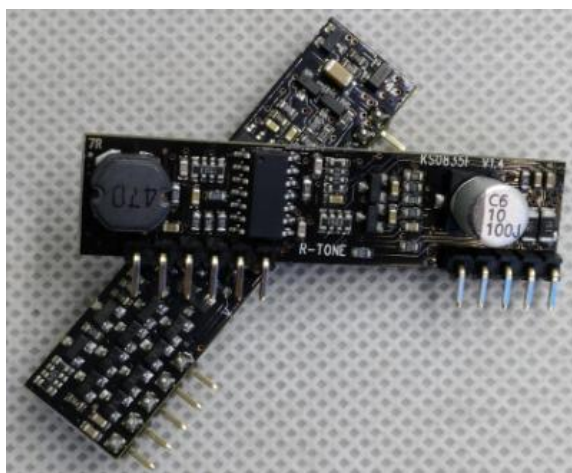

Version	Date	Author	Approved By	Remarks
V1.0	2012/3/14	LI xiao yan	Rock	
V1.1	2012/4/17	LI xiao yan	Rock	
V1.3	2012/9/6	LI xiao yan	Rock	

© 2012 Shenzhen Ring&tone Electronic Technology Co., Ltd. All rights reserved.

This document contains proprietary information of ring&tone and is not to be disclosed or used without the prior written permission of ring&tone.

Due to update and improvement of ring&tone products and technologies, information in this document is subjected to change without notice.

Features:

- Single supply voltage ring slic: +3.3V to +5.0V
- Integral high efficiency DC/DC converter.
- Highly integrated with ringing generator.
- Tip/Ring polarity reversal.
- 2 / 4 wire conversion
- Constant current feed
- High performance with low price
- Excellent sound quality
- On-Hook Transmission for caller line ID.
- Designed for GSM network
- Easy to use, with a minimum number of external components.

Applications:

- Fixed Cellular Terminals (FCT) applications.
- POS MODEM applications
- Internet Telephony (VoIP) applications.
- Fixed Wireless Terminals (FWT) applications.
- DVB Terminals applications.
- Wireless local loop (WLL) applications.
- GSM gateway

Index:

• unbalanced to ground	60dB(300Hz-3400Hz)
• Two- Wire Impedance	600R
• Four-wire return loss	>24Db
• weighted noise	-75dB
• Ringing voltage	130VP-P
• Constant current	23-31mA
• Supply Voltage	3.2V-5.5VDC

Description:

The R-TONE KS0835F is a single Subscriber Line Interface Circuit (SLIC).

The combination of features and packaging offers extremely efficient use of board area, saving significant system size and cost, minimising time to market for Telephony Systems developers.

The KS0835F has been designed to work with loop lengths of typically 1.0km

The KS0835F has integral dc/dc converter and ringing generation thus providing all the line powering requirements from a single supply.24V(off-hook)and 48V(on-hook)and 75V(ringing).

The KS0835F requires a minimum of external components, making it ideal for low line count, short loop length applications, such as WLL Terminal (WLL), Fixed Cellular Terminals (FCT), Fixed Wireless Terminals (FWT) and Internet Telephony (VoIP).

The KS0835F has an integral DC/DC converter, which generates the battery voltage in the device. This means that only a single supply of between +3.3V to +5.0V is needed, unlike conventional SLICs which will also need a battery voltage of anything between 20V and60V (75V for ringing). This confers a significant cost, space and time to market benefit on the equipment designer.

I Absolute Maximum Ratings:

	Parameter	Symbol	Min	Max	Units
1	DC Supply Voltage	VCC	-0.3	5.5	V
2	Maximum Power Dissipation, Off Hook @ 25oC	PSLIC		1.2	W
3	Operating Temperature	TOP	0	70	OC
4	Storage Temperature	TS	-40	+100	OC

I DC Electrical Characteristics*

Characte ristic	Sym	Min	Typ	Max	Units	Test Comments
Supply Current	ICC		40 50		mA	5V (on-hook) 3.3V(on-hook)
			270 320		mA	5V (off-hook) 3.3V(off-hook) during ring
			180 220		mA	5V (during ring) 3.3V(during ring)
Constant current	I _{bat}	21	23	35	mA	
Power Dissipation	P _d		30/850		mW	On/off hook (during 23mA Constant current)
Ringing voltage	V _{ing}		130		VP-P	
off-hook voltage	V _{ab}		48		V	
Supply current in power down	I _{PD}		7 5		mA mA	@ 5.0V @ 3.3V

All DC Electrical Characteristics are over the Recommended Operating Conditions with VCC at +5.0V +1%, or +3.3V +1%, unless otherwise stated.

2) Operating currents are dependent on the users application.

*Typical figures are at 25°C and are for design aid only. Not Guaranteed

I AC Electrical Characteristics*

Characteristic	Sym	Min	Typ	Max	Units	Test Comments
Two- Wire Impedance	Z0		600		Ω	
Absolute Voltage Gain	T,R-VX VR-T,R	-6 -6	0 0	6 6	dB	
Relative Gain. Referenced to 1kHz	Gf	-0.5		+0.5	dB	Over frequency range 300 to 3400 Hz
Two-wire return loss	RL	30			dB	300-3400HZ , 600R load
Four-wire return loss	THL	30			dB	300-3400HZ, 600R load
unbalanced to ground		60			dB	300-3400HZ , off-hook
common-mode rejection ratio	CMRR	45	55		dB	
weighted noise		-75			dB	
total harmonic distortion	THD	70			dB	300-3400HZ , off-hook

This applies to 3 phones with tone ringers or 2 phones with mechanical bells.

*Typical figures are at 25°C and are for design aid only.

I Pin Description:

Pin #	Name	Description
1	RING	Ring. Connects to the subscriber line Ring.
2	TIP	Tip. Connects to the subscriber line Tip.
3	F/R,25Hz	Forward/Reverse. A logic (H) will reverse the Tip and Ring voltage polarities. F/R is toggled to produce the ringing output. Logic (L) for other modes.
4	RM	Ringing Mode. Sets bias conditions during ringing. Must be set to logic (H) during ringing. Logic (L) for other modes.
5	SHK	Switch Hook. Indicates an off-hook condition when at logic (H).
6	VR	Audio In Negative. Analog input signal from the Codec (which is output on Tip and Ring).
7	VX	Audio Out. This is the analog output signal (from Tip and Ring) to the Codec.
8	NC	No Connection. Do not connect to this pin.
9	GND	DC/DC Ground. Ground input for the DC/DC converter.
10	+VDC	DC/DC Supply. +5.0V or +3.3V input for the DC/DC converter.
11	PD	Power Down DC/DC Converter. A logic (L) on this pin powers down the KS0835D. DO NOT put logic (H) on this pin.

I KS0835F Typical Connection Diagram:

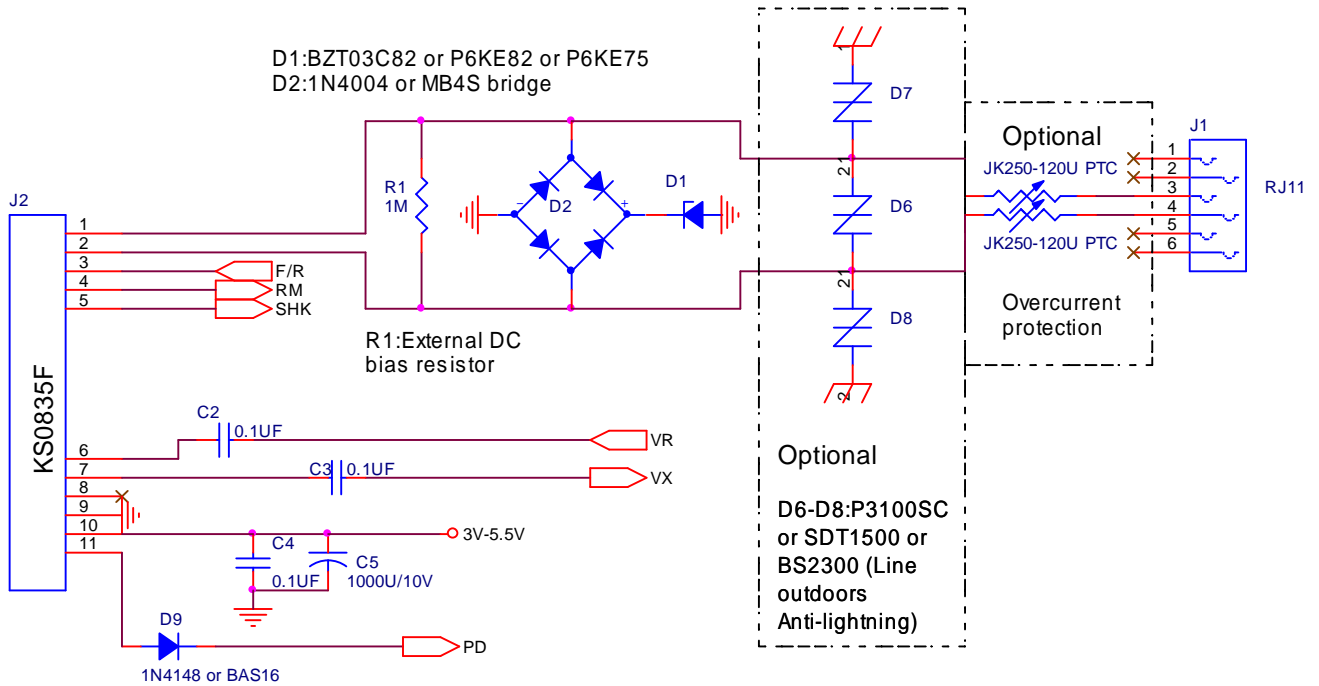

1 Ringing

The ringing signal is generated by switching the SLIC into ringing mode, by setting the RM pin high, and then toggling the F/R pin at the required frequency and cadence. The toggling of the F/R pin produces a balanced signal at Tip and Ring. During ringing the integral DC/DC converter is switched produce a battery voltage of 75V. The slope of the edges on the ringing waveform is set internally to give the correct waveform with 20Hz to 25Hz ringing frequency.

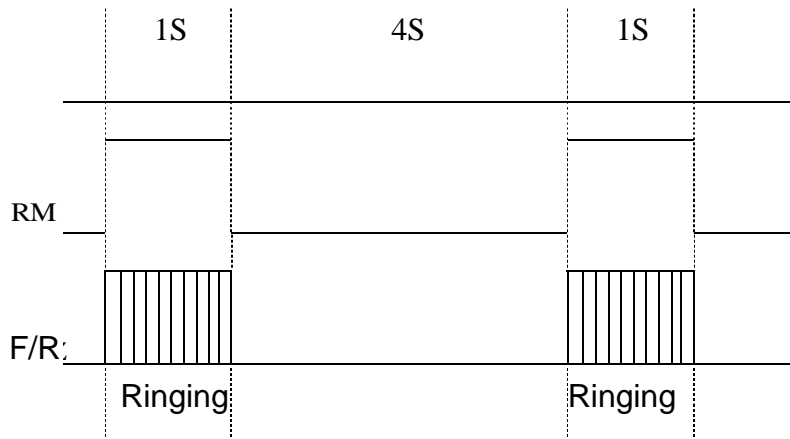

2 Tip & Ring Polarity Reversal

If F/R is held at logic (H) (Forward) the d.c. voltage at Ring is negative with respect to Tip. If F/R is taken to logic (L) (Reverse) the voltage at Ring is positive with respect to Tip.

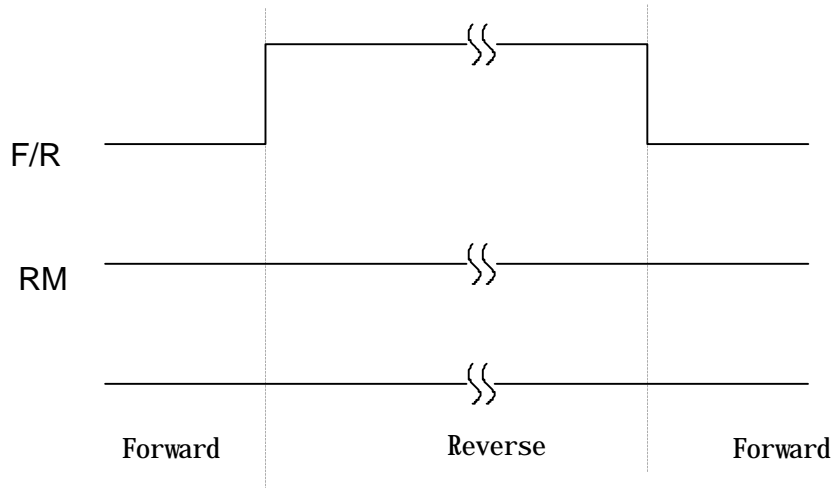

3 Switch Hook Detection

When an “off-hook” condition occurs during ringing, the ring-trip circuit on the KS0835F senses the loop current flowing and signals the off-hook condition on the SHK output. The SHK signal must be “de-bounced” (by the controlling processor) for 10ms to remove any spurious pulses. ◦

I KS0835F Product Selector

Marking	Supply Voltage (V)	Constant current feed to line (mA)	Gain 2 Wire to VOUT	Gain VIN to 2Wire	Ringing voltage (Vp-p)	Supply Current, on-hook (mA)	Supply current, off-hook (mA)	Ringing Load (REN)	Package
KS0835F	3.2~5.5	23~31	0dB	0dB	120~135	50-35	310-270	3	SIL

I Package Size: (mm ±0.3mm)

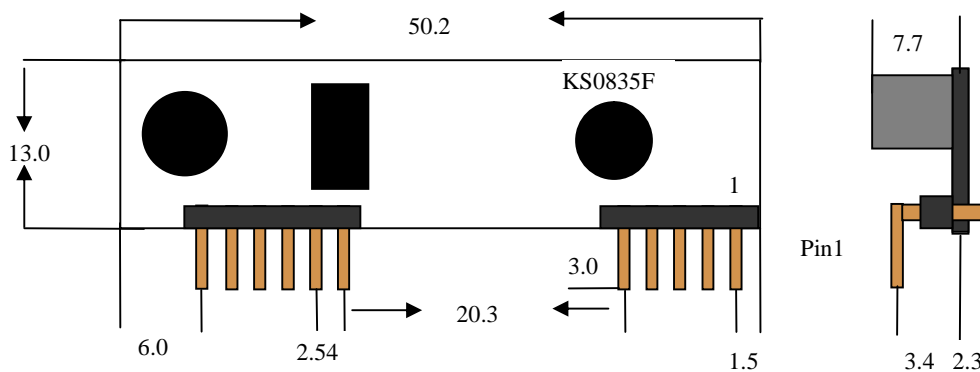

I PCB Decal : (mm ±0.3mm)

